

TPS23750 Flyback-Converter Evaluation Board – HPA108

This user's guide describes the function and operation of the HPA108 evaluation module (EVM). A complete description, schematic, bill of materials, assembly drawing, and printed-circuit board artwork are included.

Contents

1	Introduction	1
2	Specification, Schematic, and Bill of Materials	2
3	Board Layout	8
4	Using the EVM	10
5	Related Documentation	11

List of Figures

1	Typical 3.3-V PD End-to-End Efficiency	3
2	Typical 3.3-V DC/DC Converter Efficiency	3
3	Typical 5-V PD End-to-End Efficiency	4
4	Typical 5-V DC/DC Converter Efficiency	4
5	Typical Setup	10

List of Tables

1	HPA108 Electrical Specification	2
2	HPA108 Bill of Material (Rev. A)	6
3	EVM I/O Interfaces.....	10

1 Introduction

The HPA108 evaluation module implements an IEEE 802.3af-compliant class-3 power interface and a DC/DC switching converter using the Texas Instruments TPS23750 powered device (PD) controller in a typical power-over-Ethernet (PoE) configuration. The DC/DC converter provided on this EVM is a 3.3-V isolated design using a synchronous flyback topology; however, the BOM shows how to build 3.3-V or 5-V isolated and non-isolated variants. In addition, the EVM provides footprints for a simple diode and an associated snubber to implement a nonsynchronous flyback converter. A small prototype area is included on the printed-circuit board. The EVM accepts a TPS23770 in place of the TPS23750 to support a PD with a legacy undervoltage lockout (UVLO) threshold.

The EVM has separate LEDs that show when the DC/DC converter and the PoE interface are active. Test points are provided at all critical nodes. Power to the EVM is provided over the spare or data lines in an Ethernet cable or by an auxiliary source like a wall adapter.

2 Specification, Schematic, and Bill of Materials

2.1 Electrical Specification

Table 1 shows the electrical specification over a -40°C to 85°C operating temperature range. Input voltages are measured at the RJ-45 connector unless otherwise noted.

Table 1. HPA108 Electrical Specification

PARAMETER	CONDITION	MIN	TYP	MAX	UNIT	
POWER INTERFACE						
Input voltage, V_{IN}	Applied to the power pins of connectors J2 or J4	0	–	57	V	
Operating voltage	After startup. Measured at RJ-45 connector J2	36	–	57	V	
	Measured at AUX PWR connector J4	36	–	57		
Input UVLO	Rising input voltage	–	–	42	V	
	Falling input voltage	30	–	–		
Detection voltage range		2.7	–	10.1	V	
Classification voltage range		14.5	–	20.5	V	
Classification current		26	–	30	mA	
Inrush current limit		100	–	180	mA	
Operating current limit		405	–	495	mA	
DC/DC CONVERTER						
Output voltage	$36\text{ V} \leq V_{IN} \leq 57\text{ V}$, $I_{LOAD} \leq I_{LOAD}(\text{max})$	3.3-V output	3.13	3.3	3.47	V
		5-V output	4.75	5.0	5.25	
Output current, I_{LOAD}	$36\text{ V} \leq V_{IN} \leq 57\text{ V}$	3.3-V output	–	–	3	A
		5-V output	–	–	2	
Output ripple voltage, peak-to-peak	$V_{IN} = 44\text{ V}$, $I_{LOAD} = 3\text{ A}$	3.3-V output	–	15	–	mV
	$V_{IN} = 44\text{ V}$, $I_{LOAD} = 2\text{ A}$	5-V output	–	15	–	
Efficiency, end-to-end	$V_{IN} = 44\text{ V}$, $I_{LOAD} = 3\text{ A}$	3.3-V output	–	80%	–	
	$V_{IN} = 44\text{ V}$, $I_{LOAD} = 2\text{ A}$	5-V output	–	82%	–	
Switching frequency		82	–	118	kHz	

The end-to-end efficiency curves in [Figure 1](#) and [Figure 3](#) include the losses at the PD switch, bridge diode, and data transformer. The DC/DC converter efficiency curves in [Figure 2](#) and [Figure 4](#) exclude these losses. The curves are plotted for the RJ-45 connector voltages shown.

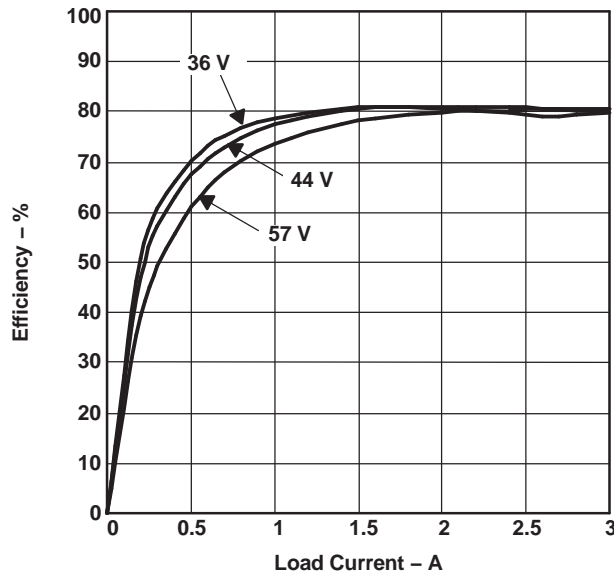

Figure 1. Typical 3.3-V PD End-to-End Efficiency

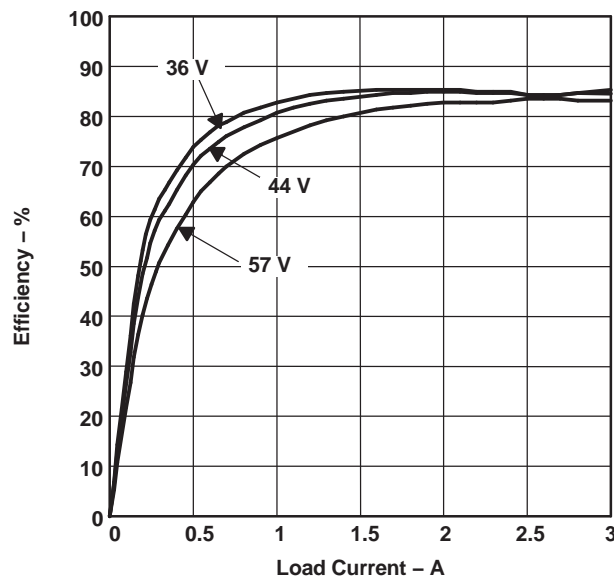

Figure 2. Typical 3.3-V DC/DC Converter Efficiency

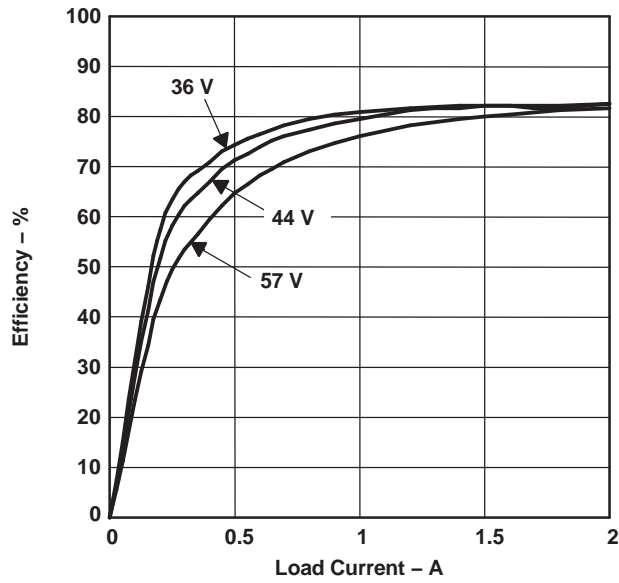

Figure 3. Typical 5-V PD End-to-End Efficiency

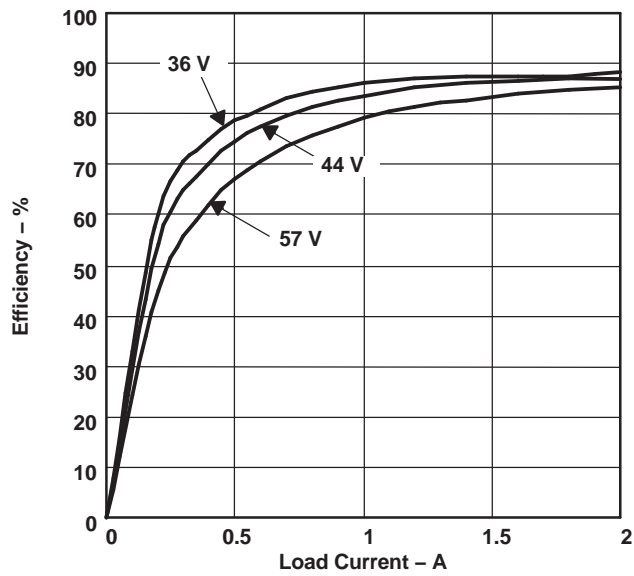
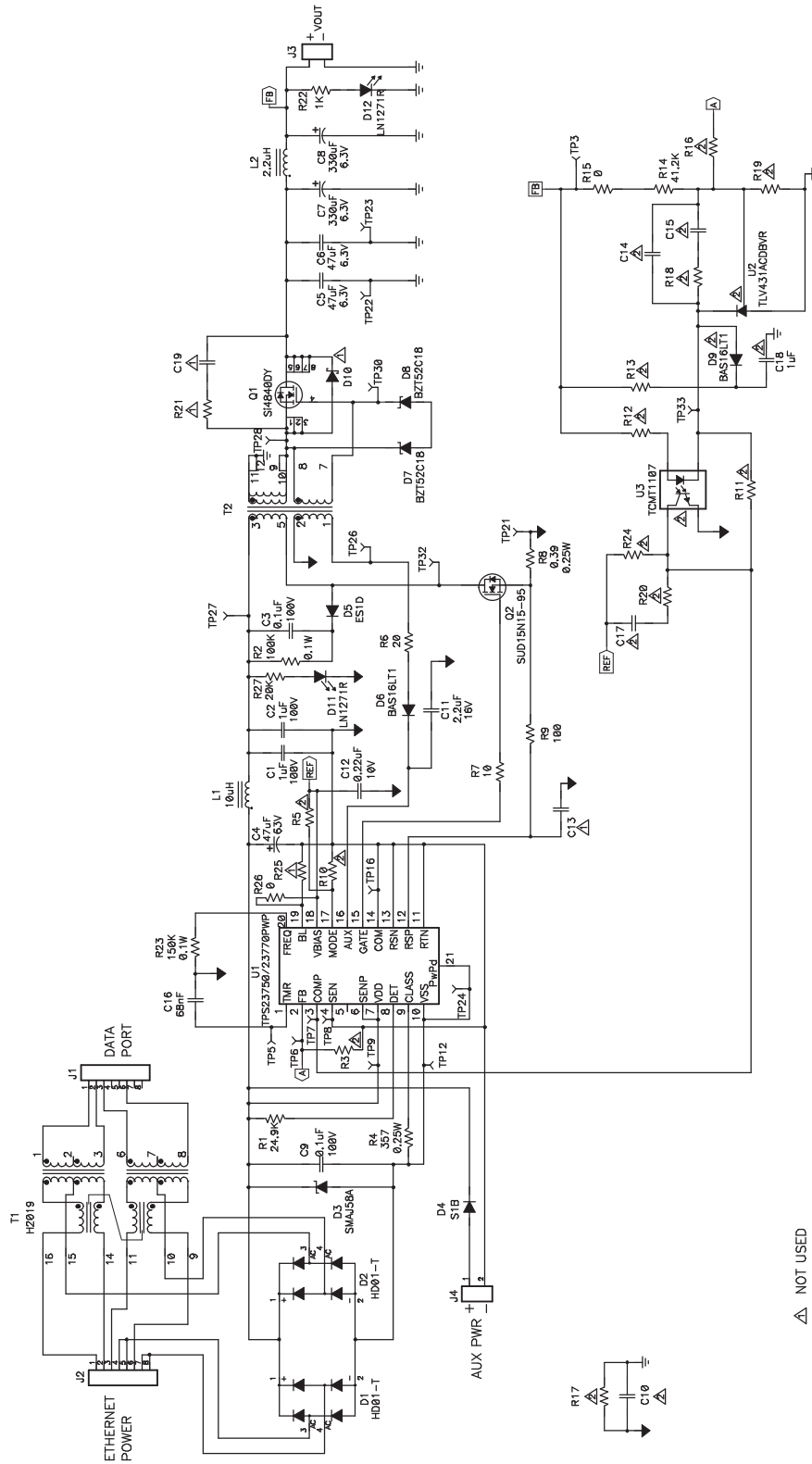

Figure 4. Typical 5-V DC/DC Converter Efficiency

2.2 Schematic



2.3 Bill of Material
Table 2. HPA108 Bill of Material (Rev. A)

Isolated		Non-Isolated		Ref Des	Description	Size	MFR	Part No.
3.3 V	5 V	3.3 V	5 V					
-001	-002	-003	-004					
Count	Count	Count	Count					
2	2	2	2	C1, C2	Capacitor, ceramic, 1 μ F, 100V, X7R, 10%	1210	Murata	GRM32ER72A105K A01L
1	1	0	0	C10	Capacitor, ceramic, 2200 pF, 2KV, X7R, 20%	1812	TDK	C4532X7R3D222KT
1	1	1	1	C11	Capacitor, ceramic, X7R, 2.2 μ F, 16-V, 10%	1206	Panasonic	ECJ-3YB1C225K
1	1	1	1	C12	Capacitor, ceramic, 0.22 μ F, 10-V, X7R	805	Std	Std
0	0	0	0	C13	Not Used	603		
1	1	0	0	C14	Capacitor, ceramic, 33 pF, 50V, C0G, 5%	603	Std	Std
0	0	1	1	C14	Capacitor, ceramic, 15 pF, 50V, C0G, 5%	603	Std	Std
1	1	0	0	C15	Capacitor, ceramic, 1000 pF, 50V, X7R, 10%	603	Std	Std
0	0	1	1	C15	Capacitor, ceramic, 680 pF, 50V, X7R, 10%	603	Std	Std
1	1	1	1	C16	Capacitor, ceramic, 68 nF, 16-V, X7R, 10%	603	Std	Std
1	1	0	0	C17	Capacitor, ceramic, 0.01 μ F, 25V, X7R, 10%	603	Std	Std
1	1	0	0	C18	Capacitor, ceramic, 1 μ F, 16V, X7R, 10%	805	Std	Std
0	0	0	0	C19	Not Used	805		
2	2	2	2	C3, C9	Capacitor, ceramic, 0.1 μ F, 100V, X7R, 10%	805	TDK	C2012X7R2A104K
1	1	1	1	C4	Capacitor, aluminum, 47 μ F, 63V, 20%	8x10mm	Panasonic	EEVFK1J470P
2	2	2	2	C5, C6	Capacitor, ceramic, 47 μ F, 6.3V, X5R, 20%	1210	TDK	C3225X5R0J476M
2	2	2	2	C7, C8	Capacitor, aluminum, SM, 330 μ F, 6.3V, 20%	8x6,2 mm	Panasonic	EEVFK0J331P
2	2	2	2	D1, D2	Bridge rectifier, 100 V, 0.8A, glass passivated, SMD	MINI DIP4	Diodes, Inc.	HD01-T
0	0	0	0	D10	Diode Schottky, 5-A, 40 V	SMC	On Semi	MBRS540T3
2	2	2	2	D11, D12	Diode, LED, red	0.114 x 0.049	Panasonic	LN1271R
1	1	1	1	D3	Diode, TVS, 58V, 1W	SMA	Diodes Inc., STMicro	SMAJ58A
1	1	1	1	D4	Diode, rectifier, 1A, 100 V	SMA	Diodes, Inc.	S1B
1	1	1	1	D5	Diode, rectifier, 1A, 200 V	SMA	On Semi	ES1D
1	1	1	1	D6	Diode, switching, 200-mA, 75V, 225 mW	SOT-23	On Semi	BAS16LT1
1	1	0	0	D9	Diode, switching, 200-mA, 75 V, 225 mW	SOT-23	On Semi	BAS16LT1
2	2	2	2	D7, D8	Diode, Zener, 200 mW, 18V	SOD-323	General Semiconductor	BZT52C18
2	2	2	2	J1, J2	Connector, Jack, Modular, 8 POS	0.705 x 0.820	AMP	520252
2	2	2	2	J3, J4	Terminal block, 2-pin, 6-A, 3,5 mm	0.27 x 0.25 in	OST	ED1514
1	1	1	1	L1	Inductor, SMT, 10 μ H, 1.1A, 160 m Ω	4.45x6.6mm	Coilcraft	DO1608C-103
1	1	1	1	L2	Inductor, SMT, 2.2 μ H, 6.1A, 15 m Ω	9.4x12.95 mm	Coilcraft	DO3316P-222HCB
1	1	1	1	Q1	MOSFET, N-ch, 40V, 14A, 9 m Ω , T _J = 25°C	SO-8	Vishay	Si4840DY
1	1	1	1	Q2	MOSFET, N-ch, 150V, 15A, 95 m Ω , T _J = 25°C	DPAK	Vishay or International Rectifier	SUD15N15-95 or iRF24N15D or iRF13N15D
1	1	1	1	R1	Resistor, chip, 24.9 k Ω , 1/16W, 1%	603	Std	Std
1	0	0	0	R12	Resistor, chip, 549 Ω , 1/16W, 1%	603	Std	Std
0	1	0	0	R12	Resistor, chip, 1.00 k Ω 1/16W, 1%	603	Std	Std
1	0	0	0	R13	Resistor, chip, 3.01 k Ω , 1/16W, 1%	603	Std	Std
0	1	0	0	R13	Resistor, chip, 1.5 k Ω , 1/16W, 1%	603	Std	Std
1	1	1	1	R14	Resistor, chip, 41.2 k Ω , 1/16W, 1%	603	Std	Std
1	0	0	0	R18	Resistor, chip, 41.2 k Ω s, 1/16W, 1%	603	Std	Std

Table 2. HPA108 Bill of Material (Rev. A) (continued)

Isolated		Non-Isolated		Ref Des	Description	Size	MFR	Part No.
3.3 V	5 V	3.3 V	5 V					
-001	-002	-003	-004					
Count	Count	Count	Count					
0	1	0	0	R18	Resistor, chip, 86.6K k Ω , 1/16W, 1%	603	Std	Std
0	0	1	1	R18	Resistor, chip, 200 k Ω , 1/16W, 1%	603	Std	Std
1	0	0	0	R19	Resistor, chip, 24.3 k Ω , 1/16W, 1%	603	Std	Std
0	0	1	0	R19	Resistor, chip, 34.8 k Ω , 1/16W, 1%	603	Std	Std
0	0	0	1	R19	Resistor, chip, 17.4 k Ω , 1/16W, 1%	603	Std	Std
0	1	0	0	R19	Resistor, chip, 13.3 k Ω , 1/16W, 1%	603	Std	Std
1	1	1	1	R2	Resistor, chip, 100 k Ω , 1/10W, 1%	805	Std	Std
1	0	0	0	R20	Resistor, chip, 249 Ω , 1/16W, 1%	603	Std	Std
0	1	0	0	R20	Resistor, chip, 0 Ω , 1/16W, 1%	603	Std	Std
0	0	0	0	R25	Not Used	603		
0	0	0	0	R21	Not Used			
1	1	1	1	R23	Resistor, chip, 150 k Ω , 0.1-W, 1%	603	Std	Std
1	1	0	0	R24	Resistor, chip, 2 k Ω , 1/16W, 1%	603	Std	Std
1	1	1	1	R27	Resistor, chip, 20 k Ω , 1/10-W, 5%	805	Std	Std
1	1	1	1	R22	Resistor, Chip, 1 k Ω , 1/10-W, 5%	805	Std	Std
1	1	0	0	R3	Resistor, chip, 0 Ω , 1/16W, 1%	603	Std	Std
1	1	1	1	R4	Resistor, chip, 357 Ω , 1/4W, 1%	1206	Std	Std
1	1	0	0	R5	Resistor, chip, 0 Ω , 1/16W, 1%	603	Std	Std
1	1	1	1	R6	Resistor, chip, 20 Ω , 1/16W, 5%	603	Std	Std
1	1	1	1	R7	Resistor, chip, 10 Ω , 1/16W, 5%	603	Std	Std
1	1	1	1	R8	Resistor, Chip, 0.39 Ω , .25W, 1%	1206	Panasonic	ERJ8RQFR39V
1	1	1	1	R9	Resistor, Chip, 100 Ω , 1/16W, 1%	603	Std	Std
2	2	2	2	R15, R26	Resistor, Chip, 0 Ω , 1/16W, 1%	603	Std	Std
0	0	1	1	R17	Resistor, Chip, 0 Ω , 1/16W, 1%	603	Std	Std
0	0	1	1	R10	Resistor, Chip, 0 Ω , 1/16W, 1%	603	Std	Std
0	0	1	1	R11	Resistor, Chip, 0 Ω , 1/16W, 1%	603	Std	Std
0	0	1	1	R16	Resistor, Chip, 0 Ω , 1/16W, 1%	603	Std	Std
1	1	1	1	T1	Xfmr, center-tapped, Voice Over IP	0.500 x 0.370	Pulse	H2019
0	1	0	1	T2	XFMR, flyback 2 Pri, 2 Sec, Custom	0.875 x 0.675	Coilcraft Pulse (ALT)	C1174-AL PA1039
1	0	1	0	T2	XFMR, flyback 2 Pri, 2 Sec, Custom	0.875 x 0.675	Coilcraft Pulse (ALT)	C1173-AL PA0691
6	6	6	6	TP12, TP16, TP21, TP22, TP23, TP24	Test Point, Black	0.038	Keystone	5001
12	12	12	12	TP3, TP5, TP6, TP7, TP8, TP9, TP26, TP27, TP28, TP30, TP32, TP33	Test Point, Red	0.038	Keystone	5000

Table 2. HPA108 Bill of Material (Rev. A) (continued)

Isolated		Non-Isolated		Ref Des	Description	Size	MFR	Part No.
3.3 V	5 V	3.3 V	5 V					
-001	-002	-003	-004					
Count	Count	Count	Count					
1	1	1	1	U1	IC, IEEE 802.3af Integrated Primary Side Controller	PWP20	TI	TPS23750PWP
1	1	0	0	U2	IC, Shunt Regulator, 1.24 V Ref, 6V, 10 mA, 1%	SOT23-5	TI	TLV431ACDBVR
1	1	0	0	U3	IC, Photocoupler, 3750VRMS, 80–160% CTR	MF4	Vishay	TCMT1107
4	4	4	4	–	Rubber bumper	–	Spec Tech	2566
1	1	1	1	–	PCB, 0 In x 0 In x 0.062 In	–	Any	HPA108

3 Board Layout

3.1 Top-Side Layout

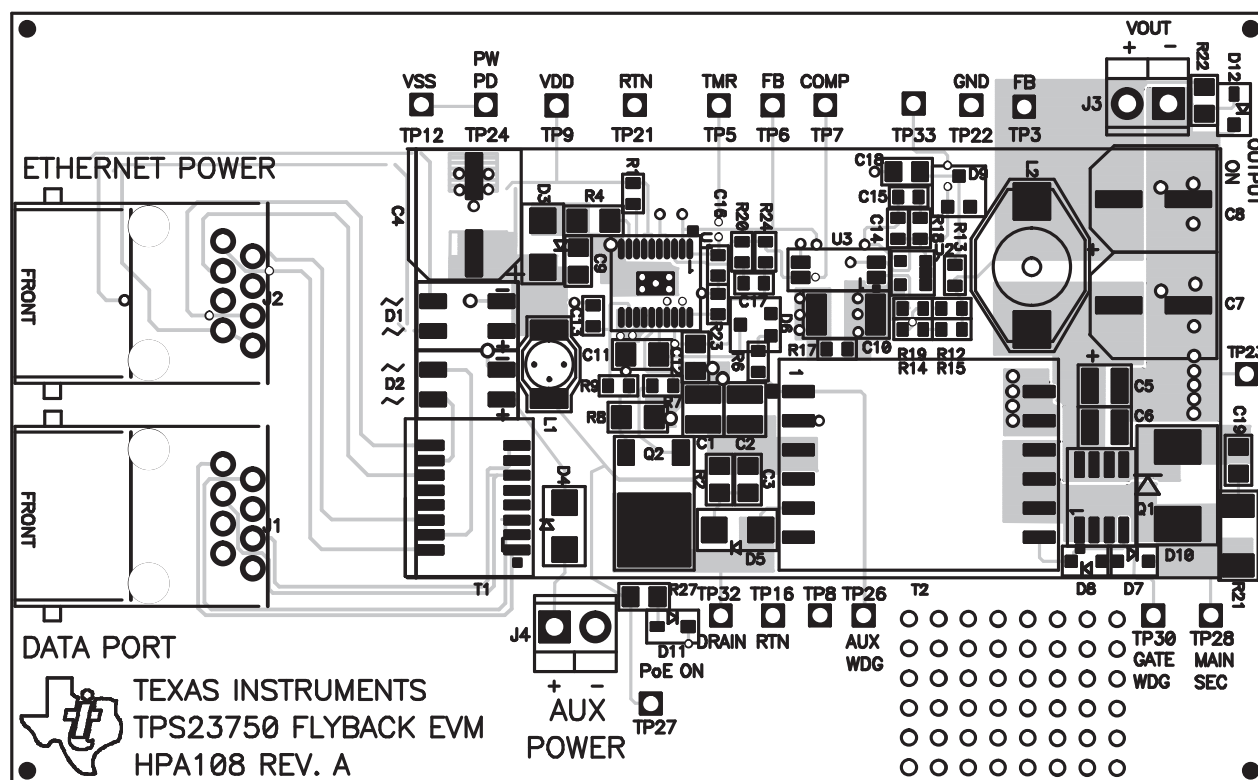

3.2 Bottom-Side Layout

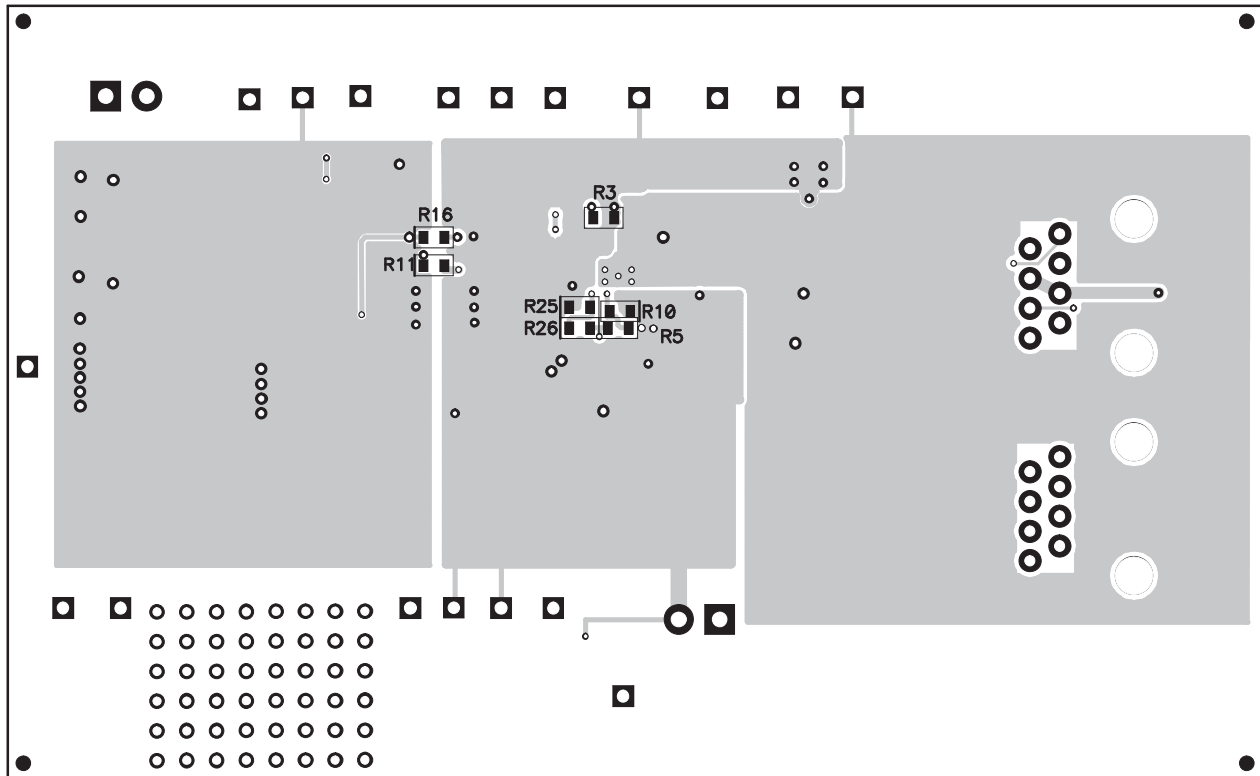

3.3 Layout Considerations

The layout of the PoE front end must use good practice for power and EMI/ESD. A basic set of recommendations include:

- The parts placement must be driven by the power flow in a point-to-point manner such as RJ-45 → Ethernet transformer → diode bridges → TVS and 0.1- μ F capacitor → TPS23750 → bulk capacitor → converter input.
- All leads should be as short as possible with wide power traces and paired signal and return.
- There should not be any crossovers of signals from one part of the flow to another.
- Spacing consistent with safety standards like IEC60950 must be observed between the 48-V input voltage rails and between the input and an isolated converter output.
- The TPS23750 should be located over split, local ground planes referenced to V_{SS} for the PoE input and to RTN for the converter operation. Whereas the PoE side may operate without a ground plane, the converter side must have one. The PowerPad™ must be tied to the V_{SS} plane or fill area, especially if power dissipation is a concern. Logic ground and power layers should not be present under the Ethernet input or the converter primary side.
- Large copper fills and *traces* should be used on SMT power-dissipating devices, and wide traces or overlay copper fills should be used in the power path.

Converter layout benefits from basic rules such as:

1. Pair signals to reduce emissions and noise, especially the paths that carry high-current pulses which include the power semiconductors and magnetics.
2. Reduce the length of all the traces in step 1.
3. Where possible, use vertical pairing.
4. Use the *ground plane* for the switching currents carefully.
5. Keep the high-current and high-voltage switching away from low-level sensing circuits including those outside the power supply.
6. The current sensing on RSP/RSN is the most critical, noise-sensitive signal. It must be protected as in

step 5, including exposure to the gate drive sign.

7. Pay special attention to spacing around the high-voltage sections of the converter.

4 Using the EVM

4.1 Setup

Figure 5 shows a typical EVM setup. The user is encouraged to read the TPS23750 data sheet before using the EVM.

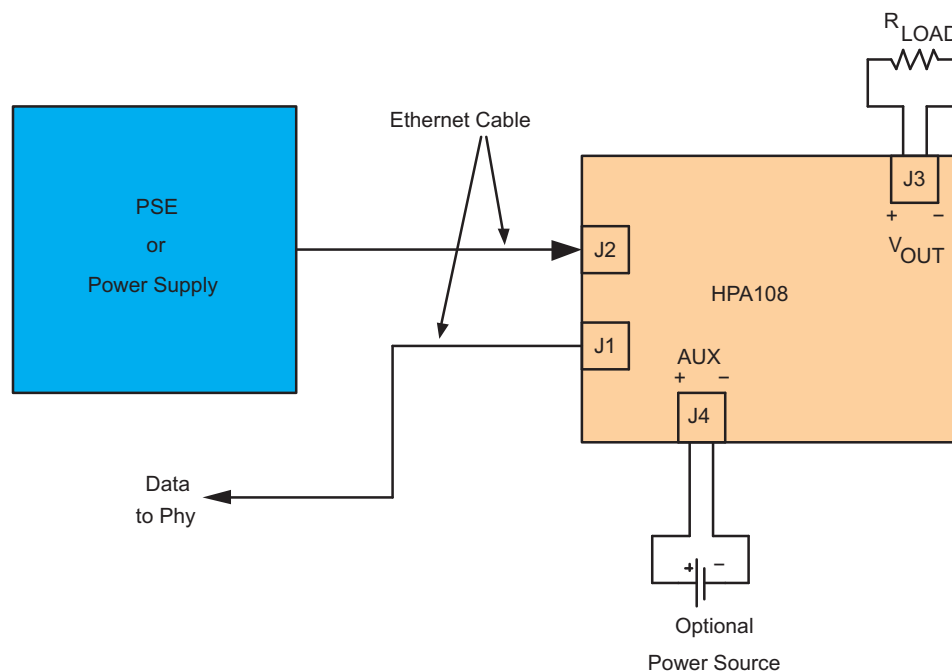

Figure 5. Typical Setup

4.2 Interface

Table 3 describes the EVM interface.

Table 3. EVM I/O Interfaces

Reference Designator	Description
J2	An Ethernet cable connects this port to the power-sourcing equipment (PSE). This port carries both data and power.
J1	This port carries only data. Do not apply power to this port.
J4	This terminal block accepts auxiliary power from a source like a wall adapter.
J3	Output voltage
D12	This LED is lit if the DC/DC converter output is on.
D11	This LED is lit if the PD FET switch is on.

4.3 Making Measurements

Stray magnetic fields from transformer T2 can couple noise into measurements. This noise may be noticeable when measuring a low-level signal like output ripple voltage. Keep the ground lead of the oscilloscope probe short and away from T2 to reduce the amount of noise pick-up.

Ground loops can be created if test equipment is connected to the EVM. Avoid ground loops by floating the test equipment and/or the power supply to the EVM.

4.4 EVM Operation

The TPS23750 data sheet describes the electrical operation and function of the various components in the isolated flyback PD. The circuit provided in the data sheet is similar to the circuit in this EVM.

5 Related Documentation

1. *TPS23750, TPS23770, Integrated 100 V IEEE 802.3af PD and DC/DC Controller* data sheet, [SLVS590](#)
2. *IEEE Std 802.3af*

EVALUATION BOARD/KIT IMPORTANT NOTICE

Texas Instruments (TI) provides the enclosed product(s) under the following conditions:

This evaluation board/kit is intended for use for **ENGINEERING DEVELOPMENT, DEMONSTRATION, OR EVALUATION PURPOSES ONLY** and is not considered by TI to be a finished end-product fit for general consumer use. Persons handling the product(s) must have electronics training and observe good engineering practice standards. As such, the goods being provided are not intended to be complete in terms of required design-, marketing-, and/or manufacturing-related protective considerations, including product safety and environmental measures typically found in end products that incorporate such semiconductor components or circuit boards. This evaluation board/kit does not fall within the scope of the European Union directives regarding electromagnetic compatibility, restricted substances (RoHS), recycling (WEEE), FCC, CE or UL, and therefore may not meet the technical requirements of these directives or other related directives.

Should this evaluation board/kit not meet the specifications indicated in the User's Guide, the board/kit may be returned within 30 days from the date of delivery for a full refund. **THE FOREGOING WARRANTY IS THE EXCLUSIVE WARRANTY MADE BY SELLER TO BUYER AND IS IN LIEU OF ALL OTHER WARRANTIES, EXPRESSED, IMPLIED, OR STATUTORY, INCLUDING ANY WARRANTY OF MERCHANTABILITY OR FITNESS FOR ANY PARTICULAR PURPOSE.**

The user assumes all responsibility and liability for proper and safe handling of the goods. Further, the user indemnifies TI from all claims arising from the handling or use of the goods. Due to the open construction of the product, it is the user's responsibility to take any and all appropriate precautions with regard to electrostatic discharge.

EXCEPT TO THE EXTENT OF THE INDEMNITY SET FORTH ABOVE, NEITHER PARTY SHALL BE LIABLE TO THE OTHER FOR ANY INDIRECT, SPECIAL, INCIDENTAL, OR CONSEQUENTIAL DAMAGES.

TI currently deals with a variety of customers for products, and therefore our arrangement with the user **is not exclusive**.

TI assumes **no liability for applications assistance, customer product design, software performance, or infringement of patents or services described herein.**

Please read the User's Guide and, specifically, the Warnings and Restrictions notice in the User's Guide prior to handling the product. This notice contains important safety information about temperatures and voltages. For additional information on TI's environmental and/or safety programs, please contact the TI application engineer or visit www.ti.com/esh.

No license is granted under any patent right or other intellectual property right of TI covering or relating to any machine, process, or combination in which such TI products or services might be or are used.

FCC Warning

This evaluation board/kit is intended for use for **ENGINEERING DEVELOPMENT, DEMONSTRATION, OR EVALUATION PURPOSES ONLY** and is not considered by TI to be a finished end-product fit for general consumer use. It generates, uses, and can radiate radio frequency energy and has not been tested for compliance with the limits of computing devices pursuant to part 15 of FCC rules, which are designed to provide reasonable protection against radio frequency interference. Operation of this equipment in other environments may cause interference with radio communications, in which case the user at his own expense will be required to take whatever measures may be required to correct this interference.

Mailing Address: Texas Instruments, Post Office Box 655303, Dallas, Texas 75265
Copyright © 2006, Texas Instruments Incorporated

EVM WARNINGS AND RESTRICTIONS

It is important to operate this EVM within the input voltage range of 0 V to 57 V.

Exceeding the specified input range may cause unexpected operation and/or irreversible damage to the EVM. If there are questions concerning the input range, please contact a TI field representative prior to connecting the input power.

Applying loads outside of the specified output range may result in unintended operation and/or possible permanent damage to the EVM. Please consult the EVM User's Guide prior to connecting any load to the EVM output. If there is uncertainty as to the load specification, please contact a TI field representative.

During normal operation, some circuit components may have case temperatures greater than 100°C. The EVM is designed to operate properly with certain components above 100°C as long as the input and output ranges are maintained. These components include but are not limited to linear regulators, switching transistors, pass transistors, and current sense resistors. These types of devices can be identified using the EVM schematic located in the EVM User's Guide. When placing measurement probes near these devices during operation, please be aware that these devices may be very warm to the touch.

Mailing Address: Texas Instruments, Post Office Box 655303, Dallas, Texas 75265
Copyright © 2006, Texas Instruments Incorporated

IMPORTANT NOTICE

Texas Instruments Incorporated and its subsidiaries (TI) reserve the right to make corrections, modifications, enhancements, improvements, and other changes to its products and services at any time and to discontinue any product or service without notice. Customers should obtain the latest relevant information before placing orders and should verify that such information is current and complete. All products are sold subject to TI's terms and conditions of sale supplied at the time of order acknowledgment.

TI warrants performance of its hardware products to the specifications applicable at the time of sale in accordance with TI's standard warranty. Testing and other quality control techniques are used to the extent TI deems necessary to support this warranty. Except where mandated by government requirements, testing of all parameters of each product is not necessarily performed.

TI assumes no liability for applications assistance or customer product design. Customers are responsible for their products and applications using TI components. To minimize the risks associated with customer products and applications, customers should provide adequate design and operating safeguards.

TI does not warrant or represent that any license, either express or implied, is granted under any TI patent right, copyright, mask work right, or other TI intellectual property right relating to any combination, machine, or process in which TI products or services are used. Information published by TI regarding third-party products or services does not constitute a license from TI to use such products or services or a warranty or endorsement thereof. Use of such information may require a license from a third party under the patents or other intellectual property of the third party, or a license from TI under the patents or other intellectual property of TI.

Reproduction of information in TI data books or data sheets is permissible only if reproduction is without alteration and is accompanied by all associated warranties, conditions, limitations, and notices. Reproduction of this information with alteration is an unfair and deceptive business practice. TI is not responsible or liable for such altered documentation.

Resale of TI products or services with statements different from or beyond the parameters stated by TI for that product or service voids all express and any implied warranties for the associated TI product or service and is an unfair and deceptive business practice. TI is not responsible or liable for any such statements.

TI products are not authorized for use in safety-critical applications (such as life support) where a failure of the TI product would reasonably be expected to cause severe personal injury or death, unless officers of the parties have executed an agreement specifically governing such use. Buyers represent that they have all necessary expertise in the safety and regulatory ramifications of their applications, and acknowledge and agree that they are solely responsible for all legal, regulatory and safety-related requirements concerning their products and any use of TI products in such safety-critical applications, notwithstanding any applications-related information or support that may be provided by TI. Further, Buyers must fully indemnify TI and its representatives against any damages arising out of the use of TI products in such safety-critical applications.

TI products are neither designed nor intended for use in military/aerospace applications or environments unless the TI products are specifically designated by TI as military-grade or "enhanced plastic." Only products designated by TI as military-grade meet military specifications. Buyers acknowledge and agree that any such use of TI products which TI has not designated as military-grade is solely at the Buyer's risk, and that they are solely responsible for compliance with all legal and regulatory requirements in connection with such use.

TI products are neither designed nor intended for use in automotive applications or environments unless the specific TI products are designated by TI as compliant with ISO/TS 16949 requirements. Buyers acknowledge and agree that, if they use any non-designated products in automotive applications, TI will not be responsible for any failure to meet such requirements.

Following are URLs where you can obtain information on other Texas Instruments products and application solutions:

Products		Applications	
Amplifiers	amplifier.ti.com	Audio	www.ti.com/audio
Data Converters	dataconverter.ti.com	Automotive	www.ti.com/automotive
DSP	dsp.ti.com	Broadband	www.ti.com/broadband
Interface	interface.ti.com	Digital Control	www.ti.com/digitalcontrol
Logic	logic.ti.com	Military	www.ti.com/military
Power Mgmt	power.ti.com	Optical Networking	www.ti.com/opticalnetwork
Microcontrollers	microcontroller.ti.com	Security	www.ti.com/security
RFID	www.ti-rfid.com	Telephony	www.ti.com/telephony
Low Power Wireless	www.ti.com/lpw	Video & Imaging	www.ti.com/video
		Wireless	www.ti.com/wireless

Mailing Address: Texas Instruments, Post Office Box 655303, Dallas, Texas 75265
Copyright © 2007, Texas Instruments Incorporated